

Double Glazed Unit:*
 27mm toughened and heat strengthened laminated
 16mm argon filled cavity with TGI "warm edge" spacer
 10.8mm laminated low 'E' float
 *Please see the box at bottom right for full specification

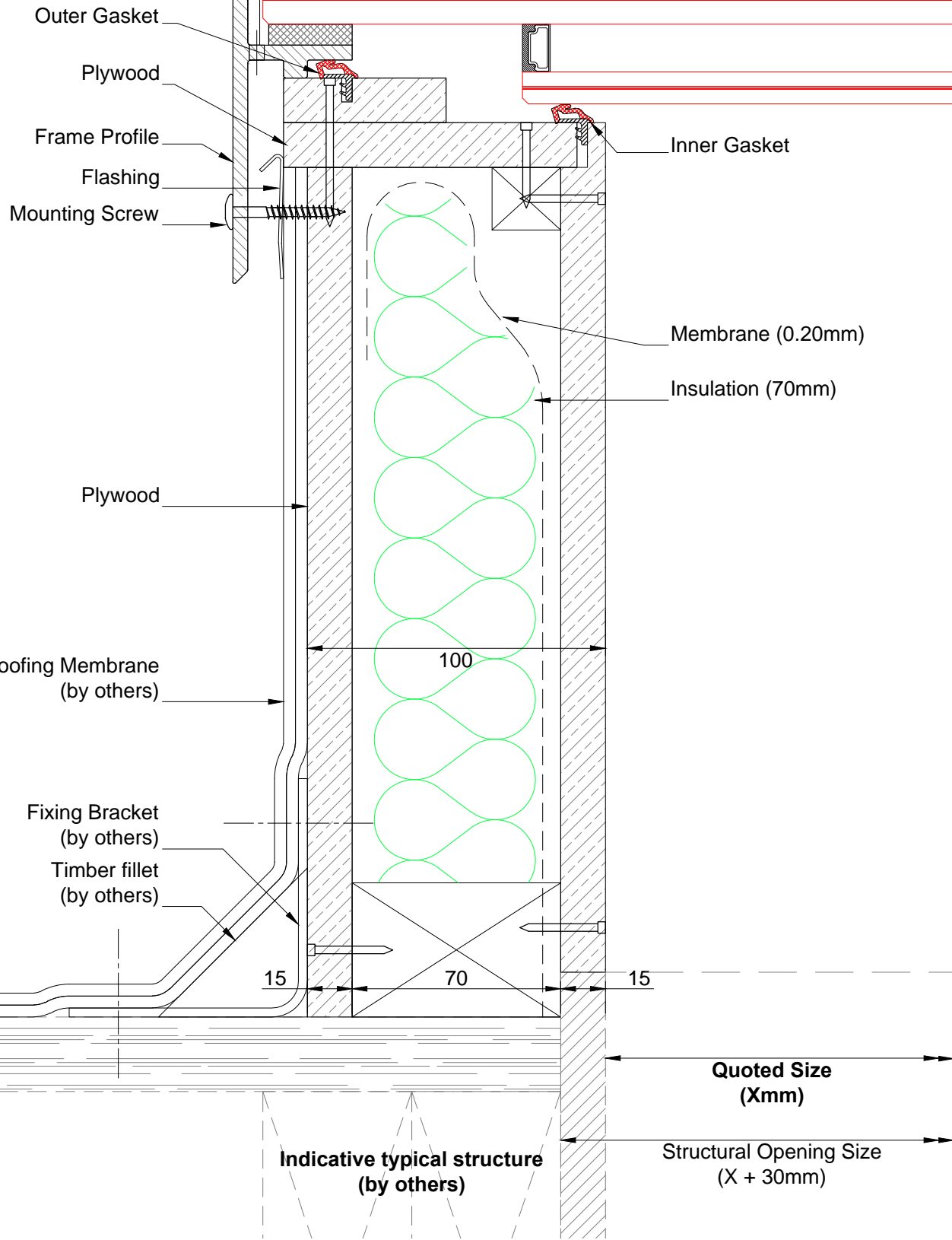

SCALE 1:2 @ A3

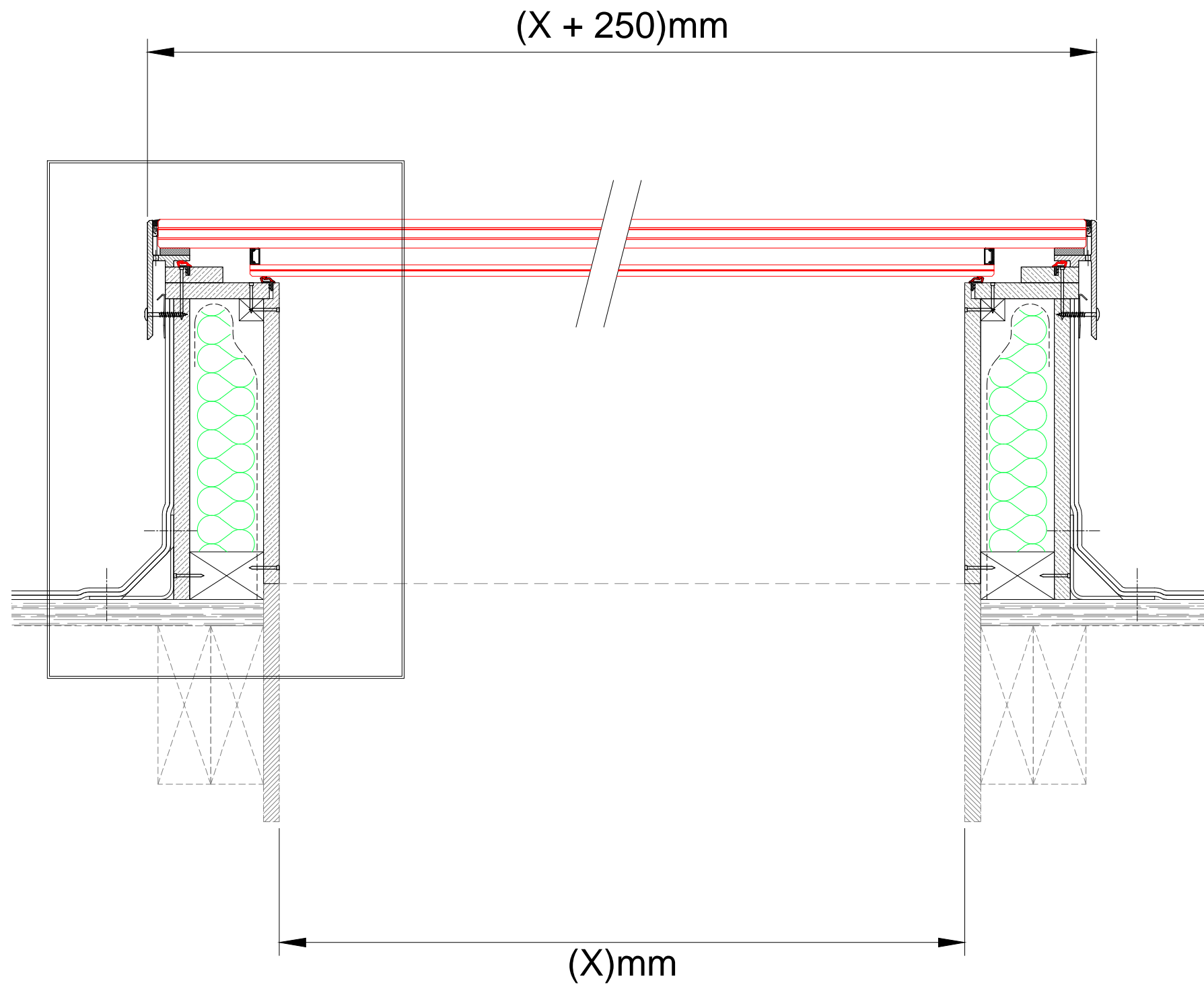

SCALE 1:5 @ A3

* GLASS SPECIFICATION:		
Outer Pane (27.04mm laminated):	Internal Void (16mm):	Inner Pane (10.76mm laminated):
8mm clear toughened heat strengthened	16mm Argon filled cavity	5mm clear float with low 'E' coating
1.52mm laminate interlayer		0.76mm laminate interlayer
8mm clear heat strengthened float		5mm clear float
1.52mm laminate interlayer		
8mm clear heat strengthened float		



VELUX Company Ltd.
 Woodside Way
 Glenrothes
 Fife
 Scotland
 KY7 4ND
 Telephone:
 +44 (0) 1592 778 246

WALK-ON (with 300mm upstand)
 (glass suitable for "Large Size")